

# NOTICE

Note that when converting this document from its original format to a .pdf file, some minor font and format changes may occur causing slight variations. When viewing and printing this document, we cannot guarantee that your specific PC or printer will support all of the fonts or graphics. Therefore, when you view the document fonts may be substituted and your individual printer may not have the capability to print the document correctly.

# *Installation Instructions for Elite ITH-4D/8D/16D-2/3 D<sup>term</sup> IPK Terminals and the IP-R(IPK) Adapters*

Control No. 750319-0 (Document Revision 5)

## **General Information**

The Elite IPK ITH-4D/8D/16D-2/3 provides connection to an IAD(8)-U( ) ETU with Megaco Station Package on the Electra Elite IPK or a PVA with MG 16 package on the Electra Elite IPK II.

When you already have an Elite IPK (DTH) Terminal, inserting the IP-R(IPK) Adapter into the plug-in connector on the bottom of the Elite IPK Terminal transforms the telephone into an IP station. The user can connect a PC to the LAN through an RJ-45 Ethernet jack on the IP-R(IPK) Adapter to act as a hub.

Any Elite IPK IP-enabled terminal in conjunction with the IAD(8)-U( ) ETU (Megaco Station Package) or PVA with MG 16, enables IP Telephony stations for the Electra Elite IPK or IPK II systems. The IP stations can be used to provide connectivity with the Corporate Elite over the LAN (Ethernet) or via high speed Ethernet connection.

## **IP-R(IPK) Adapter Specifications**

Table 1 lists the specifications for the IP-R(IPK) Adapter.

**Table 1 IP-R(IPK) Adapter Specifications**

<b>Feature</b>	<b>Specification</b>
Interface	10/100 Base-T (IEEE 802.3), RJ-45
Protocol	Voice (UDP, RTP, and RTCP) Signal (TCP, H.225 and H.245)
Jitter Buffer	Max 90 ms
QOS	Network Managed switches supporting Type of Service (TOS) field and VLAN support
Local Power	27 V 750 mA via AC Adapter Base
Applications	TFTP (Client), DHCP Client, Megaco (H.248)
Standards	UL1459, FCC Part 68
Voice Specifications	G.711 (PCM Mu-law/A-law) G.729
Mountable D <sup>term</sup>	D <sup>term</sup> 8D, 16D, 32D-type telephone 4D

## Applying Power to the ITH-8D/16D-2/3 $D^{term}$ IPK Terminals

---

Figure 1 shows the connections on the  $D^{term}$  IPK Terminals.

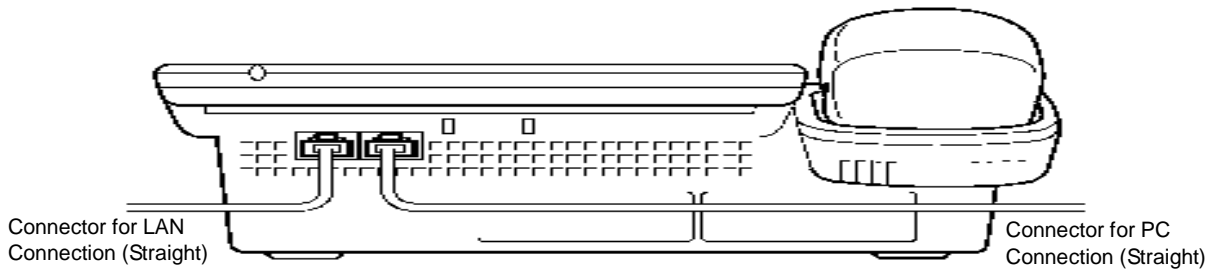

Figure 1 Rear View of  $D^{term}$  IPK Terminal

## Applying Power to the ITH-8D/16D-2/3 $D^{term}$ IPK Terminals

---

Two methods can be used to provide power the to ITH-8D/16D-2/3  $D^{term}$  IPK Terminals:

1. AC-( )R Unit (AC Adapter)

Plug the optional AC-( )R Unit input jack into the ITH-8D/16D-2/3  $D^{term}$  IPK Terminal base as shown in Figure 2.

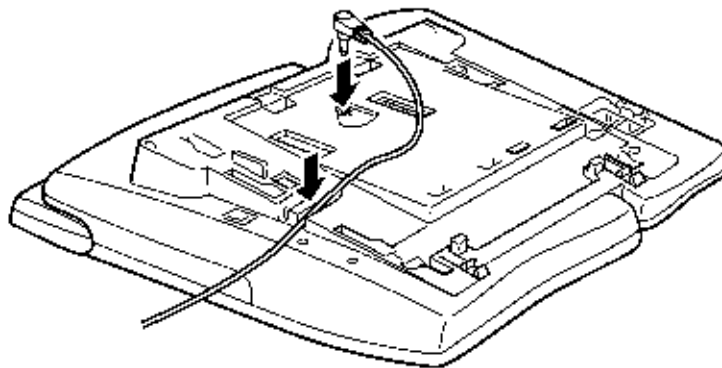
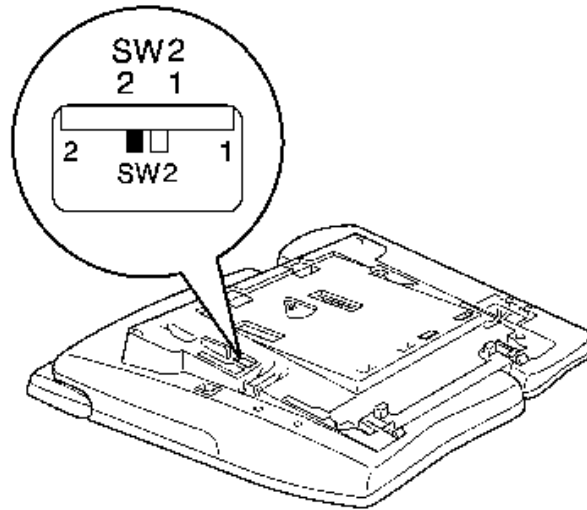

Figure 2 Applying Power to the ITH-8D/16D-2/3  $D^{term}$  IPK Terminal using an AC-( )R Unit

## 2. Power over the Ethernet (POE)

Power over the Ethernet (POE), sometimes called In-Line Power, is a LAN technology that allows standard 10/100 Base-T data cables to pass electrical current from a power source to a requesting-end device. [Figure 3](#) shows the SW2 switch.



**Figure 3 ITH Switch Settings for Power Assignment**

The IP-R(IPK) Adapter has a switch setting (SW2) that is used to select between two POE methods.

To set the switches for the different power supply methods, refer to [Table 2 Setting Switches for Power Configurations](#).

**Table 2 Setting Switches for Power Configurations**

	Switch (SW2) Settings	Power Method	Equipment Used
ITH-8/16D-2 IP-R	1	NEC POE Equipment	<input type="radio"/> NEC Power Patch Panel SN1604 PRWMS (Stock No. 59022) <input type="radio"/> NEC BF200/24 POE Switching Hub
	2 (Default)	CISCO Equipment (CDP)	<input type="radio"/> Cisco Catalyst PRW Series <input type="radio"/> Cisco Powered Patch Panel
ITH 8D/16D-3	1 (Default)	AF	<input type="radio"/> IEEE 802.3 af compliant switch
	2	Cisco	<input type="radio"/> Cisco Catalyst PRW Series <input type="radio"/> Cisco Powered Patch Panel

 When using a AC-( )R to power an IP terminal, always use position 1 on SW2.

### 3. Power Sources for ITH-4D-3 Terminal

Refer to [Figure 4](#). Two power sources are available:

- Using an AC-( )R Unit (AC Adapter)
- Using IEEE802.3af compatible power over an Ethernet Switching HUB

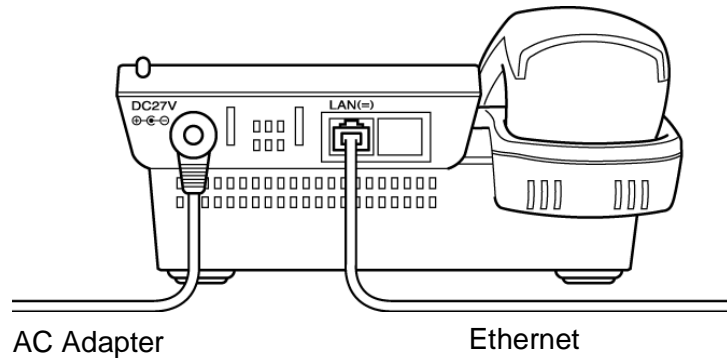

Figure 4 ITH-4D-3 Terminal Power Sources

## Installing the IP-R(IPK) Adapter on the Elite IPK Terminal

---

The IP-R(IPK) Adapter can be installed on the Elite IPK Terminal (DTH-8D/16D/32D-1/2). The procedures in this section show how to install the adapter.

1. Prepare the Elite IPK Terminal for adapter installation by unplugging the telephone cord from the terminal. Then turn the terminal upside down and locate the tabs.

Raise the tilt leg by pressing the areas indicated on the diagram.

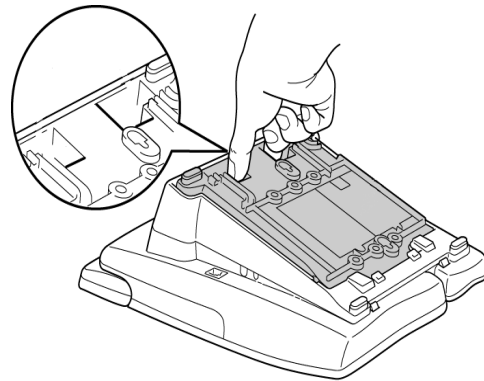

2. Grasp the middle of the hollow spaces at the top and pull up until the retaining tabs click to raise the Base Plate.

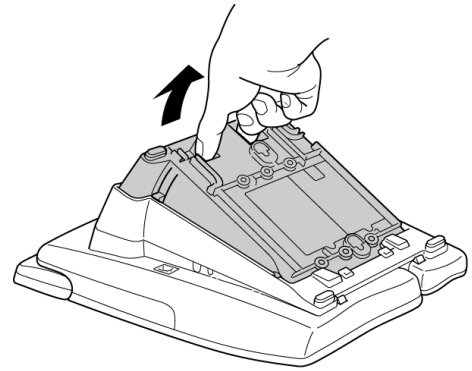

3. Press down on the tabs indicated in the illustration and push forward on the base plate to remove it.

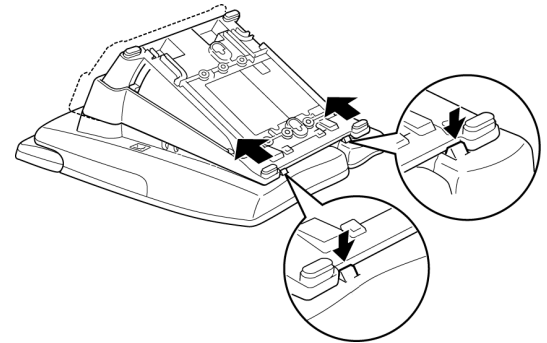

4. When an adapter is installed for the first time in a terminal, the base cover on the Multiline Terminal must be modified. Two adapters can be installed in the Multiline Terminal, and two separate cutouts are provided. Remove the applicable cutout/cutouts on the bottom of the base plate with nippers. When only one adapter is being installed and it needs an AC-( )R Unit for power, remove only the right cutout as shown in the illustration.

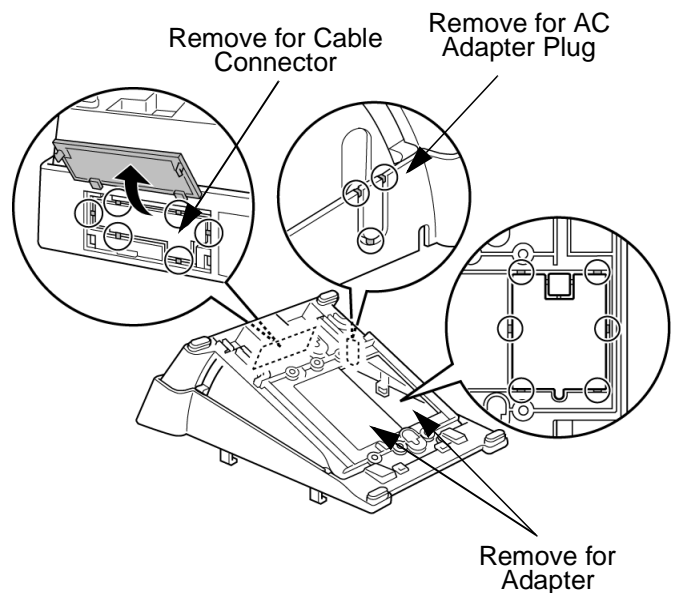

5. Plug the IP-R (IPK) Adapter into Connector 1 on the Elite IPK Terminal (DTH-8D/16D/32D-1/2) as indicated in the diagram.

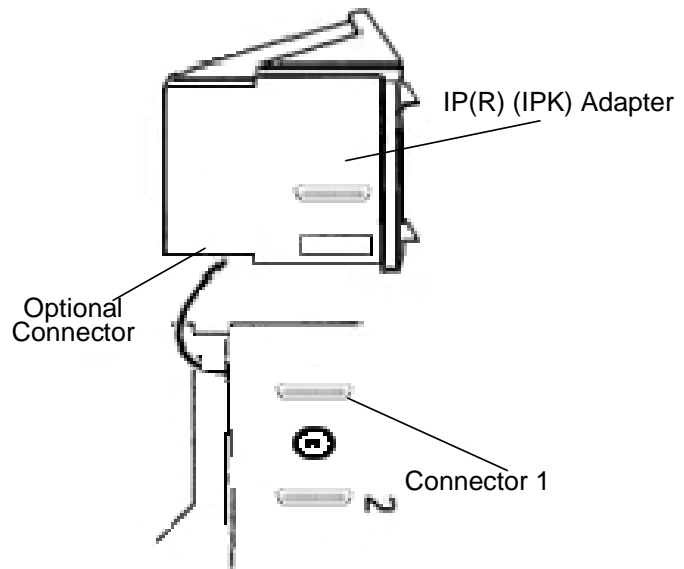

6. Attach the base plate again by lining up the four tabs on the base cover with their corresponding slots on the telephone as illustrated.
7. Slide the cover in the direction of the arrows until it clicks in place.

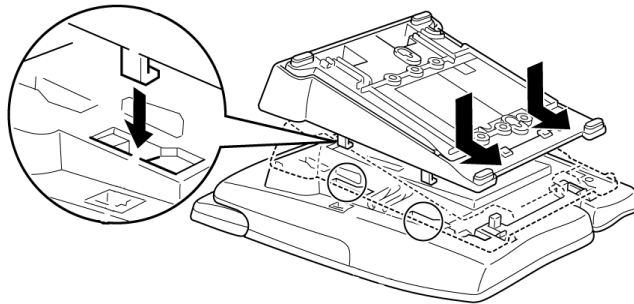

## Connection Example

---

Figure 5 shows a typical connection using a DTH Terminal equipped with an IP-R(IPK) Adapter or ITH-4D/8D/16D-2/3 terminal.

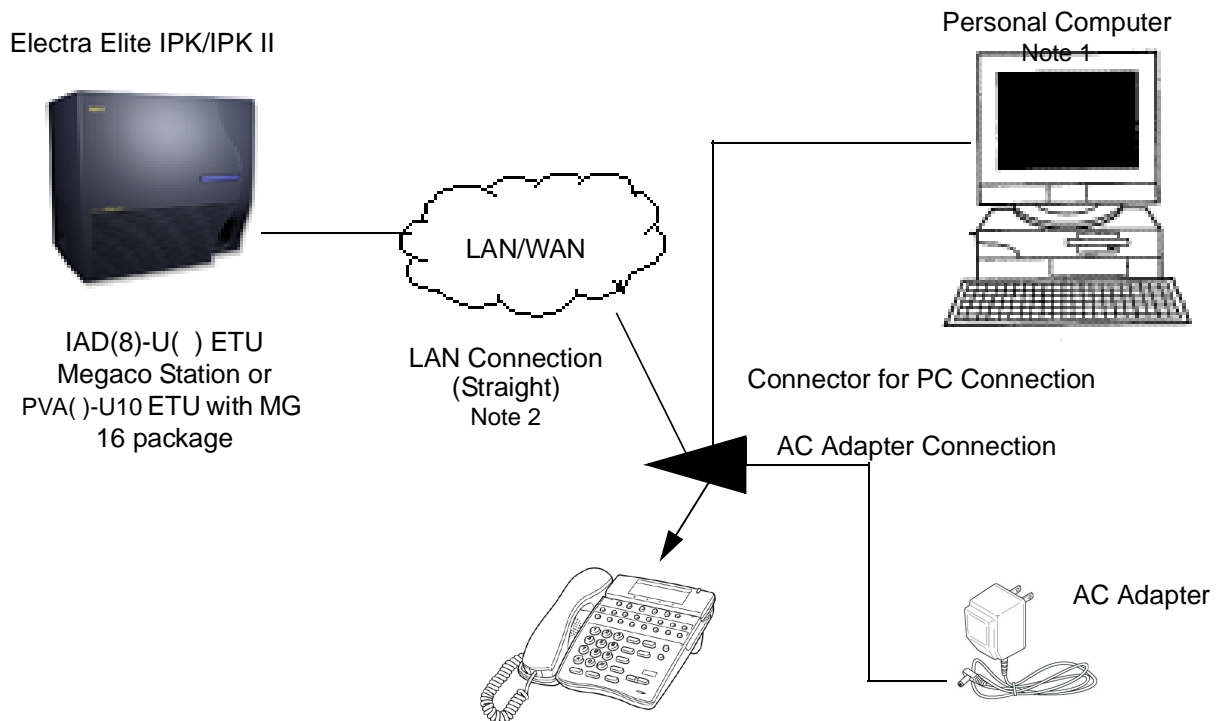

Note 1: The IP-R(IPK) Adapter and ITH terminal are equipped with a switching Hub function, enabling connection to a personal computer.

Note 2: When using 10 Base-T, a straight cable category 3 or higher is required (maximum length 100 meters). When using 100 Base-TX, a straight cable category 5 or higher is required (maximum length 100 meters).

Figure 5 Connection Example

## Requirements

---

To configure the ITH-4D/8D/16D-2/3 or IP-R(IPK) Adapter, the following units are required.

- ITH-4D/8D/16D/2/3  $D^{term}$  IPK Terminal equipped with an AC-( )R power supply unit, or POE (Power over Ethernet).
- Any Elite IPK Terminal (DTH-8D/16D/32D-1) and IP-R(IPK) Adapter and AC-( )R power unit, or POE (Power over Ethernet).
- Ethernet Cable

Use the following table to record the configuration information. **Before** filling in the information, consult your Network Administrator to confirm the network settings. This device can be configured using DHCP or Static IP addressing.









Setting	Information	Comments
IP Address		Not required if DHCP is used.
Subnet Address		Not required if DHCP is used.
Extension Number		Not required if Static IP is used.
Router IP Address		Default Gateway. Not required if DHCP is used.
MGC IP Address		This is the IP address of the IAD(8)-U( ) Megaco Station ETU or PVA( )-U10 with MG 16.















Headsets that have open-style receivers (i.e., Mirage, DuoSet and DuoPro) can cause echo problems on the ITH terminals. The echo suppression and receiver gain of the phone determines the severity of the echo when using any headset. Please recognize that due to the environment where the phone/headsets are located, ambient noise may affect performance. Please refer to NEC for the recommended headset to use for VoIP applications.

## Quick Setup

---

This section provides the step-by-step procedures for setting up and configuring the ITH-4D/8D/16D-2/3 or IP-R(IPK) Adapter. For a more detailed description of the programming menu and the various programming options, refer to [Programming the ITH-4D/8D/16D-2/3 and/or IP-R\(IPK\) Adapter on page 9](#).

- Connect the LAN port of the ITH-4D/8D/16D-2/3 and/or IP-R(IPK) Adapter to the network and the PC port to an optional PC at your workstation. Plug in the AC-( )R Unit to add power to this unit.
  -  The ITH-4D-3 terminal does not have a PC port.
- The ITH-4D/8D/16D-2/3 and/or IP-R(IPK) Adapter automatically attempts to locate the DHCP server when powered up. Wait until the server lookup times out, and DHCP Server is Not Found is displayed on the telephone, and then begin programming.
- Press    and  to enter the basic programming mode.
- The **Programming Menu** is displayed. Press  to display the **Network Settings** options. This enables you to configure IP settings for IP Terminals.
- Press  (DHCP mode is displayed). Press the corresponding digit (**1** or **2**) to enable or disable DHCP mode; then press  (the softkey that corresponds with **Set** on the LCD).
  -  When DHCP is not used (Static IP assignment), select **1** (Disable), then select **Set**, and proceed to step **6**. When DHCP is used, select **2** (Enable - factory default) and proceed to step **9**.

6. From the **Network Settings** option, press  and enter the IP Address (XXX.XXX.XXX.XXX); then press  (the softkey that corresponds with **Set** on the LCD).
7. From the **Network Settings** option, press  and enter the Subnet Mask (XXX.XXX.XXX.XXX); then press  (the softkey that corresponds with **Set** on the LCD).
8. From the **Network Settings** option, press  and enter the Router IP Address (XXX.XXX.XXX.XXX); then press  (the softkey that corresponds with **Set** on the LCD). To return to **Programming Menu**, press  (the softkey that corresponds with **Prev** on the LCD).
9. Press  from the **Programming Menu** to access the MGC (Media Gateway Controller) IP Address and enter the IP Address for IAD(8)-U( ) ETU Megaco Station or PVA( )-U10 with MG 16 (XXX.XXX.XXX.XXX); then press  (the softkey that corresponds with **Set** on the LCD).
10. Press  from the **Programming Menu** to access the **Extension Number** option. Enter the extension number and press  (the softkey that corresponds with **Set** on the LCD).
  -  The extension number is used to register the IP telephone with the IAD(8)-U( ) Megaco Station ETU or PVA( )-U10 with MG 16. These settings must match the Electra Elite IPK Programming Station Number Assignment in Memory Block 4-10. *This entry is required if DHCP mode is enabled.*
11. Press  from the **Programming Menu** to access **Advanced Settings** option.
12. Select **3, DRS Settings**.
13. Select **1, DRS Mode, Disable this function**.
14. This function must be disabled prior to saving the configuration.
15. Select  (Save); the system stores the new configuration and performs a software reset.
16. After the unit performs the software reset, the ITH-4D/8D/16D-2/3 and/or IP-R(IPK) Adapter searches for the MGC. After the unit locates the MGC, the telephone LCD restores the system time, and the softkeys for System, Station, Up, Down are restored.
17. Your ITH-4D/8D/16D-2/3 and/or IP-R(IPK) Adapter is now ready for operation.

## Programming the ITH-4D/8D/16D-2/3 and/or IP-R(IPK) Adapter

---

Before the ITH-4D/8D/16D-2/3 Terminals and IP-R(IPK) Adapters can function on your network, they must be programmed. This section provides instructions for various programming functions. The Programming menu allows you to access: DHCP Mode, IP Address, Subnet Mask, Router IP Address, Extension Number, Volume settings, VLAN setting, and view all system information.

## Programming Menu

To enter programming mode:

Press **Hold**, **Transfer**, **\*** and **#**.

The Programming Menu is displayed. Use the Up and Down softkeys to scroll the menu selections. Nine menu selections are available from this menu.

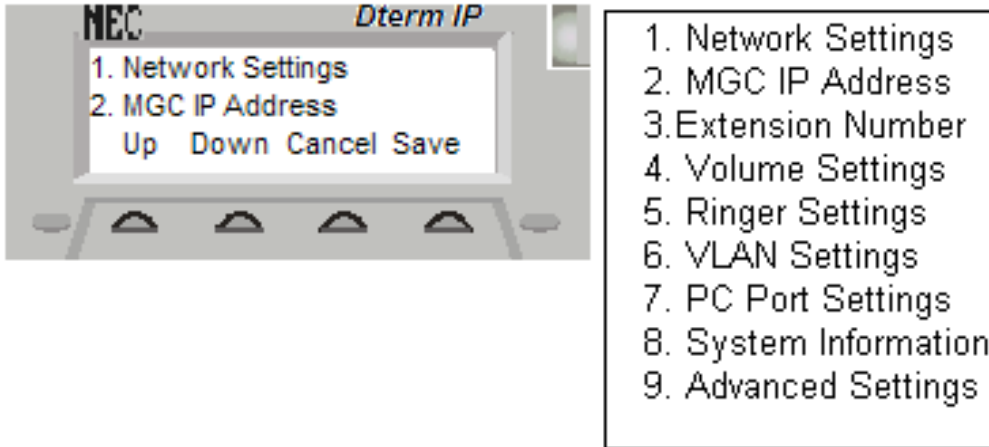

### 1. Network Settings

This menu option allows IP Terminals or Adapter IP settings to be configured or is used to enable DHCP.

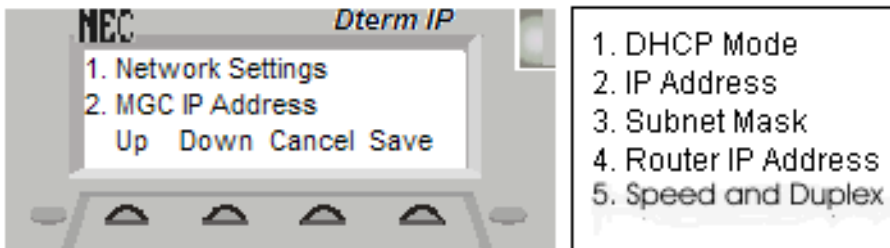

#### ○ 1. DHCP Mode

The IP-R(IPK) Adapter and ITH have a built-in DHCP client to obtain and assign IP parameters (IP Address, Default Gateway, etc.) automatically from a DHCP server.

When DHCP mode is enabled, the IP-R(IPK) Adapter and ITH obtain IP parameters automatically. When disabled, the parameters in items 2 to 5 (lists on the menu) must be programmed manually.

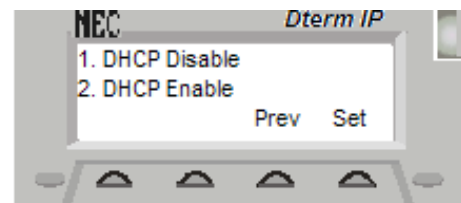

 DHCP Mode is enabled at default.

○ 2. IP Address

Each IP-R(IPK) Adapter and ITH Terminal requires a unique IP Address on the network when DHCP is not enabled. The network administrator can provide a static IP Address for each ITH and IP-R(IPK) Adapter in the network. When used in a DHCP environment this option is not applicable.

 The IP Address is not assigned at default.

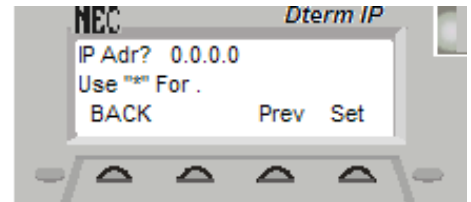

○ 3. Subnet Mask

The network administrator can provide the subnet mask to be used for the ITH and IP-R(IPK) Adapter. Typically, this is the same value you use on your other equipment in the network. When used in a DHCP environment, this option is not applicable.

 The Subnet Mask Address is not assigned at default.

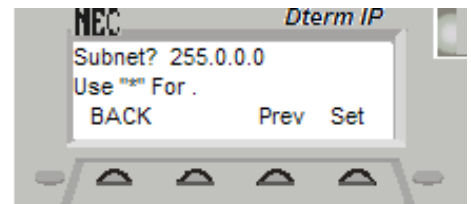

○ 4. Router IP Address

This is the address of the default gateway for the ITH and IP-R(IPK) Adapter. The network administrator can provide the address of the default gateway for the subnet. This is a critical parameter for the operation of the ITH and IP-R(IPK) Adapter that is not in the same subnet as the IAD(8)-U( ) Megaco Station/PVA( )-U10 ETU with MG 16.

When used in a DHCP environment, this option is not applicable.

 The Router IP Address is not assigned at default.

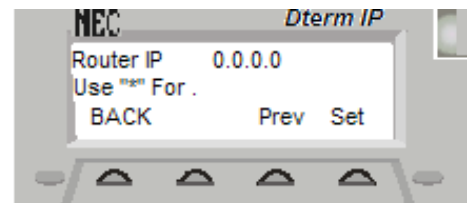

○ 5. Speed and Duplex (used to select Network Speed and Duplex)

- Autonego
- 100 M Full
- 100 M Half
- 10 M Full
- 10 M Half

## 2. MGC IP Address

This menu option is used to assign the MGC (Media Gateway Controller) IP address. The MGC IP Address should match the IP Address assigned to the Electra Elite IPK IAD(8)-U( ) Megaco Station or PVA( )-U10 with MG 16.

 The MGC IP Address is not assigned at default.

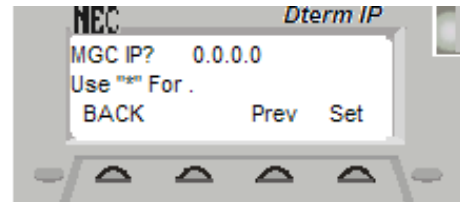

## 3. Extension Number

The Extension Number field is used to register an IP Telephone with the IAD(8)-U( ) Megaco Station ETU or PVA( )-U10 with MG 16 when DHCP mode is being used.

 The Extension Number set in the ITH and IP-R(IPK) Adapter must match the Station Number Assignment in Key System Programming. Refer to the Electra Elite IPK or IPK II Programming Manual.

 Zero (0) is assigned at default.

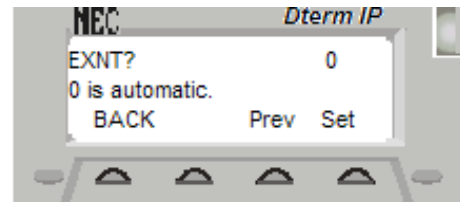

## 4. Volume Setting

Volume setting submenus can be assigned on a scale of 1 to 13. Each submenu item changes the volume control for the respective audio unit. You can change the Ringer, Handset, Headset, Speaker, LCD Contrast, or Side Tone Control.

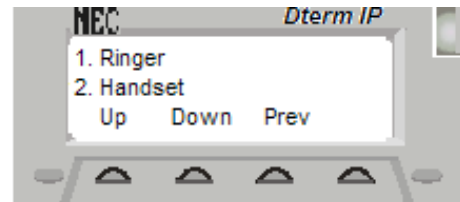

## 5. Ringer Settings

Ringer settings allow a user to enable distinctive ringing for IP stations. When Custom Ring mode is enabled, the user can assign one of eight distinctive ring patterns. The following table lists the ring selections and their associated patterns.

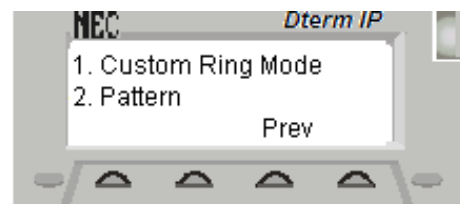

Ring Selection	Pattern
1 = High	520+660Hz, 16Hz Modulation Signal
2 = Middle	520+660Hz, 8Hz Modulation Signal
3 = Low	1400+ 1100 Hz
4 = Tone Ring 1	1100Hz
5 = Tone Ring 2	540Hz
6 = Tone Ring 3	1100+1400Hz, 16Hz Modulation Signal
7 = Tone Ring 4	660+760Hz, 16Hz Modulation Signal
8 = Tone Ring 8	1100Hz Envelope Signal

## 6. VLAN Settings

VLAN allows a network to be segmented logically without having to be physically wired. When VLAN Mode is enabled for the ITH and IP-R(IPK) Adapter, the network administrator can provide the VLAN ID and the Priority setting.

 VLAN Mode is disabled at default.

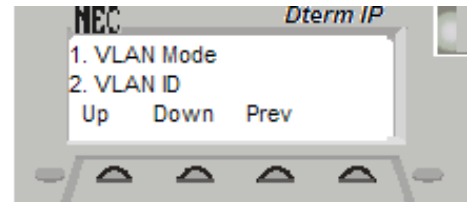

## 7. PC Port Settings

This option allows users to configure the PC port on the IP Terminal VLAN Settings.

 This option is not available for the ITH-4D-3 terminal. It has no PC port to provide physical connection.

1. PC Port Vlan Mode
  - Port Vlan Disable
  - Port Vlan Enable
2. PC Port Vlan ID
  - (0 ~ 4094)
3. PC Port Vlan Priority
  - (0 ~ 7)

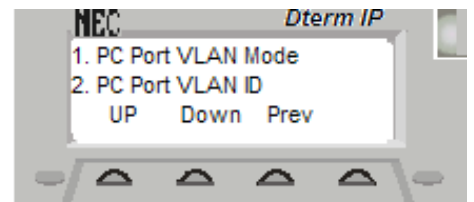

## 8. System Information

System Information displays configured information for various modes used in the system, for IP Addresses, Subnet Masks, and the firmware version.

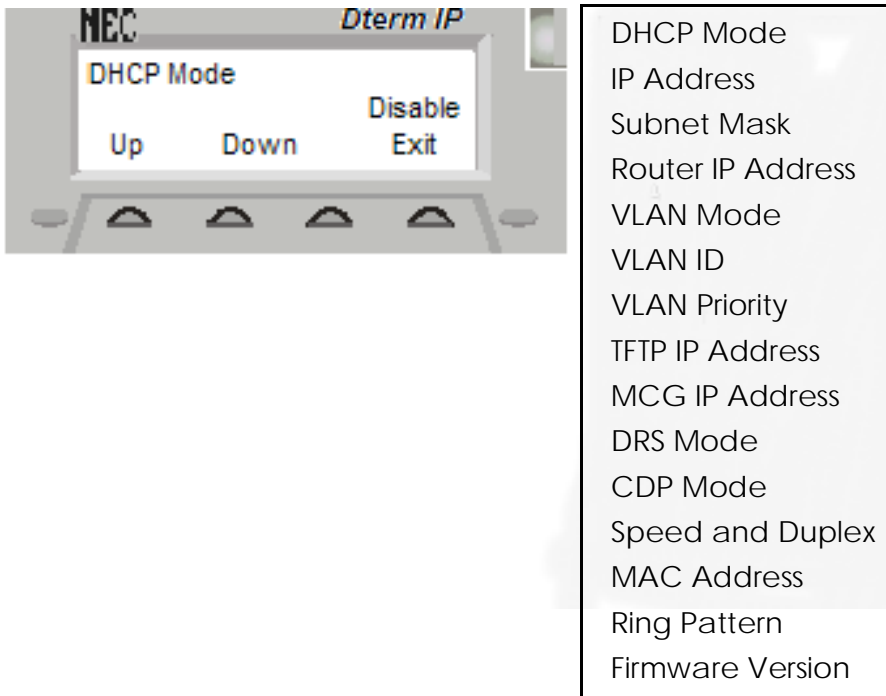

 These options are read-only.

## 9. Advanced Settings

This menu option allows user to perform advanced operations. The user can set the parameters for download mode, perform a soft reset, reset the system to the factory default settings, or run a diagnostic utility.

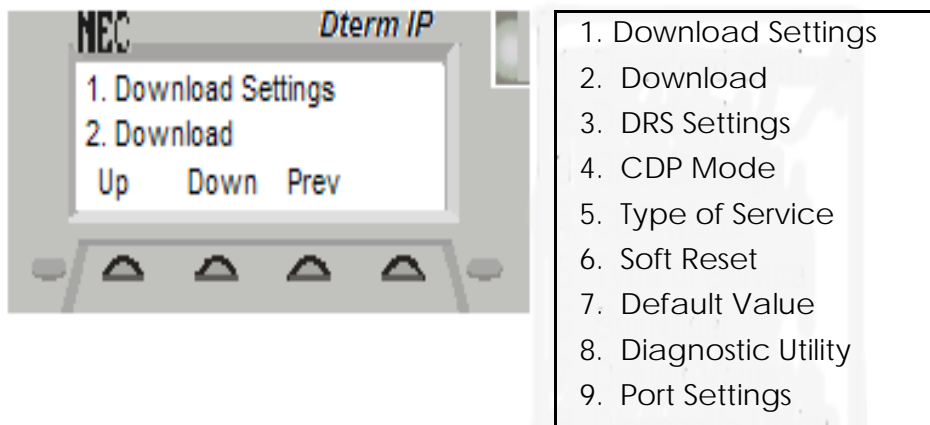

○ 1. Download Setting

When upgrading IP-R(IPK) Adapter or ITH-4D/8D/16D-2/3 Terminals select the download mode (TFTP is the only applicable value), select 2 and enter the Server IP Address. (Format: xxx.xxx.xxx)

 Assign the IP Address of the client PC where the target TFTP server is located.

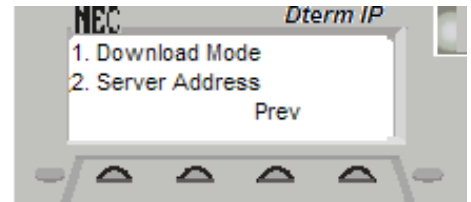

○ 2. Download

The Download option initiates the actual file transfer between TFTP Server and Client.

Option #1 Program: Downloads the hex file and maintains all previous configurations.

Option #2 Configuration: Downloads the default configuration file deleting all previous configurations.

Option #3 Boot & Program: Down loads the new hex file and the boot file.

The following table provides firmware file names for the ITH-4D/8D/16D-2/3 Terminals and IP-R(IPK) Adapters.

Type	Program File Name	Configuration Name
ITH-4D/8D/16D-2/3	apph248.out	config.ini
IP-R(IPK) Adapter	apph248.hex	config.ini

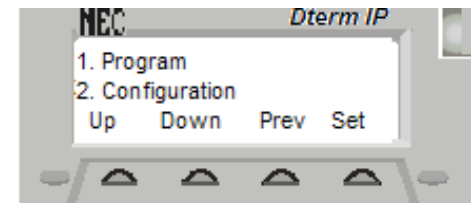

○ 3. DRS Settings

DRS (*D<sup>term</sup>* Registration Server) Settings are not used when integrating with the IAD(8)-U( ) Megaco Station ETU or PVA( )-U10 with MG 16. This is being reserved for future use.

 This function is Disabled at factory default.

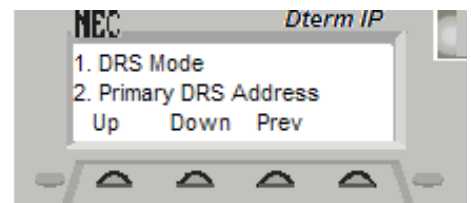

○ 4. CDP Mode

CDP (Cisco Discovery Protocol) Mode allows the terminal to detect and use inline power methods used by many Cisco devices.

 This function is Disabled at factory default.

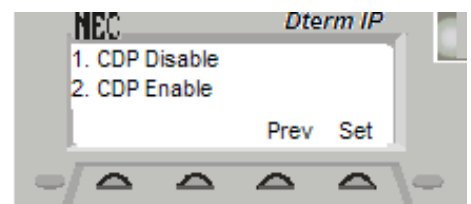

○ 5. Type of Service

This field enables a user to set Quality of Service using ToS (Type of Service) for RTP (Real-Time Transport Protocol), Megaco, or DRS ( $D^{term}$  Registration Server).

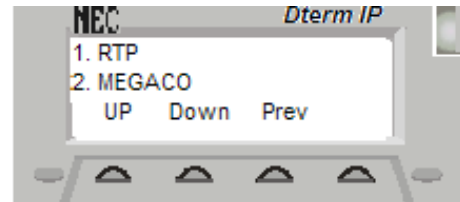

○ 6. Soft Reset

This option allows a software reset.

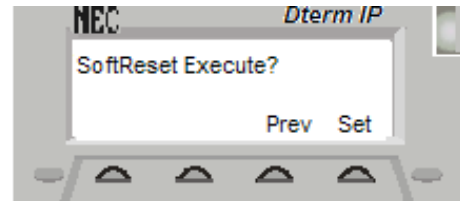

○ 7. Default Value Reset

Selecting this option restores the factory default configuration.



***ALL existing configuration settings will be lost!***

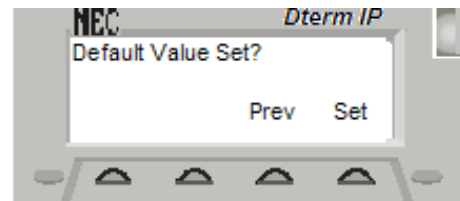

○ 8. Diagnostic Utility

This ping utility is used to assist in troubleshooting, allowing users to ping additional IP Terminals on the IP network.

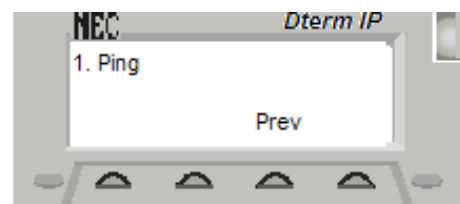

○ 9. Port Settings

- MGC Mate Port
- MGC Self Port
- RTP Port 1
- RTP Port 2

 Refer to the IPK Megaco Station Manual for configure samples and detailed settings.

## 1 MGC Mate Port

Port number used to communicate with the Mate device  
Default 2944

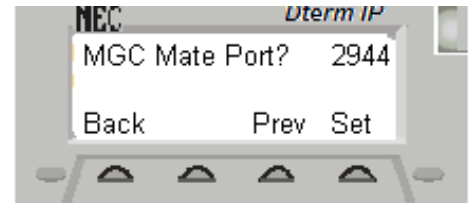

## 2 MGC Self Port

Port number used by terminal to communicate  
Default 2944

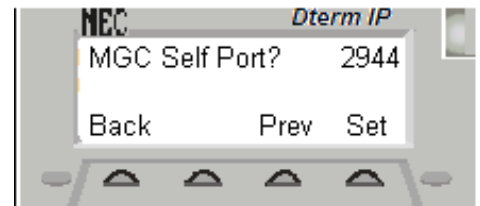

## 3 RTP Port 1

Audio path primary port for communication  
Default 49152

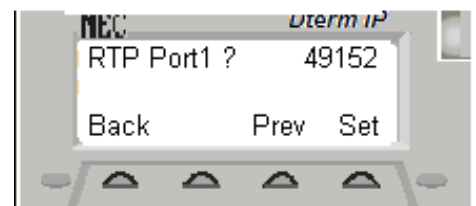

## 4 RTP Port 2

Backup audio port used in audio communication  
Default 49154

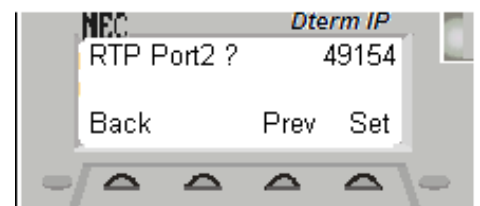

**THIS PAGE INTENTIONALLY LEFT BLANK**